



## GPSMAP® 3000 Series Installation Instructions

The GPSMAP 3000 series chartplotter and GPS antenna must be properly installed according to the following instructions. You need the appropriate fasteners, tools, and mounts listed in each section. These items are available at most marine dealers. Always wear safety goggles, ear protection, and a dust mask when drilling, cutting, or sanding. When drilling or cutting, always check what is on the opposite side of the surface. Mount the GPSMAP 3000 series chartplotter in a location that provides a clear, glare-free view of the display and easy operation of the controls or touch screen. **If you experience difficulty installing the chartplotter, seek the assistance of a professional installer; or contact Garmin® Product Support by phone at 913/397.8200 or 800/800.1020. Go to [www.garmin.com/support](http://www.garmin.com/support). In Europe, contact Garmin (Europe) Ltd. at 44/0870.8501241.**

Before installing your GPSMAP 3000 series chartplotter, confirm that the package contains the items listed on the box. If any parts are missing, contact your Garmin dealer immediately.

**WARNING:** See the *Important Safety and Product Information* guide in the product box for product warnings and other important information.

### To install the GPSMAP 3000 series chartplotter:

1. Mount the GPSMAP 3000 series chartplotter ([Page 1](#)).
2. Mount the GPS antenna ([Page 3](#)).
3. Connect the GPSMAP 3000 series device to power and to the GPS antenna ([Page 6](#)).
4. Ensure the chartplotter software is up-to-date ([Page 10](#)).

### Although they are not necessary to use the GPSMAP 3000 chartplotter, you can also use this manual to:

- Connect the chartplotter to NMEA 0183-compatible devices such as a VHF radio with DSC ([Page 6](#)).
- Connect the chartplotter to an external alarm ([Page 8](#)).
- Connect the chartplotter to a video input source ([Page 8](#)).
- Connect the chartplotter to an external video monitor ([Page 8](#)).
- Connect the chartplotter to other Garmin Marine Network compatible devices, such as a sounder or a radar ([Page 9](#)).

## Mounting the GPSMAP 3000 Series Chartplotter

You can use the included bracket to bail mount the chartplotter, or you can use the included template and hardware to flush mount the chartplotter.

### Bail Mounting the GPSMAP 3000 Series Chartplotter

Use the included bracket to bail mount the GPSMAP 3000 series chartplotter.

#### Tools required (not included):

- Drill and drill bit
- Screwdriver
- Pencil
- Mounting hardware (screws or nuts, washers, and bolts)

 **NOTE:** The mounting hardware (screws or nuts, washers, and bolts) are not included. The holes on the bail mount are  $\frac{5}{16}$  in. (7.9 mm) in diameter. Choose mounting hardware that fits the holes in the bail mount and securely attaches it to your specific mounting surface. The size of the drill bit required depends on the mounting hardware chosen.

**To install the bail-mount bracket ①:**

1. Using the bail mount as a template, mark the location of the four mounting holes. Be sure to leave at least 2 in. (5.1 cm) of clearance behind the GPSMAP 3000 series chartplotter for the wiring.

**NOTE:** Mount a GPSMAP 3005C/3205C chartplotter 10 in. (25 cm), a GPSMAP 3006/3206C chartplotter 12 in. (30 cm), and a GPSMAP 3010C/3210C chartplotter 24 in. (60 cm) from a magnetic compass to avoid interference.

2. Using an appropriately sized drill bit, drill the pilot holes for your mounting hardware.
3. Secure the bail mount to the surface with your mounting hardware.

**To install the GPSMAP 3000 series chartplotter on the bail-mount bracket ②:**

1. Loosely attach the mounting knobs to the GPSMAP 3000 series chartplotter.
2. Slide the chartplotter onto the bail mount, and tighten the mounting knobs.



**Flush Mounting the GPSMAP 3000 Series Chartplotter**

Use the included flush-mount template and hardware to flush mount your GPSMAP 3000 series chartplotter.

**NOTE:** Make sure the surface on which you mount the chartplotter has at least 2 in. (5.1 cm) of open space behind it to fit the chartplotter and the connected wires.

**NOTE:** Mount a GPSMAP 3005C/3205C chartplotter 10 in. (25 cm), a GPSMAP 3006/3206C chartplotter 12 in. (30 cm), and a GPSMAP 3010C/3210C chartplotter 24 in. (60 cm) from a magnetic compass to avoid interference.

**Hardware (included):**

- Flush-mount template
- Four threaded mounting studs
- Four flat washers
- Eight hex nuts

**Tools required (not included):**

- Jigsaw
- Masking tape
- Scissors
- Drill
- Drill bits— $1/8$ " (3 mm) and  $3/8$ " (6 mm)
- $1/16$  in. (2 mm) Allen (Hex) wrench
- 4 mm socket or wrench
- Marker
- Center punch and hammer

**To flush mount a GPSMAP 3000 series chartplotter:**

1. The flush-mount template is included in the product box. Trim the template and ensure it will fit in the location at which you want to flush mount the chartplotter.
2. Trim the flush-mount template and tape it to the location at which you want to mount the chartplotter.
3. Using a  $3/8$  in. (10 mm) drill bit, drill one or more of the four pilot holes inside the corner of the template to begin cutting the mounting surface.

- Using the jigsaw, cut the mounting surface along the inside of the solid line indicated on the flush-mount template. Use a file and sandpaper to refine the size of the hole. **Be very careful when cutting this hole. There is only a small amount of clearance between the case and the mounting holes.**
- Install the four mounting studs into the chartplotter by screwing the shorter, threaded section into the back of the chartplotter. Use the  $\frac{1}{16}$  in. (2 mm) Allen wrench to tighten the mounting studs until they stop. **Do not overtighten - you may damage the mounting stud or the mounting holes.** The studs are coated with a reusable thread-locking patch applied at the factory.
- Place the chartplotter in the hole and make sure that the mounting studs line up with the pilot holes on the flush-mount template after cutting, sanding, and filing the hole. If they do not, mark the locations where the studs will feed through the mounting surface.
- Using the center punch, indent the center of each of the 4 mm mounting-hole locations.
- Using a  $\frac{1}{8}$  in. (3 mm) drill bit, drill the four mounting holes.
- Place the chartplotter into the cutout. The four mounting studs should feed through the four mounting holes drilled in Step 8.
- Place the flat washers over the mounting studs, then thread the hex nuts onto the mounting studs. Tighten all four hex nuts evenly until the chartplotter is snug against the mounting surface.

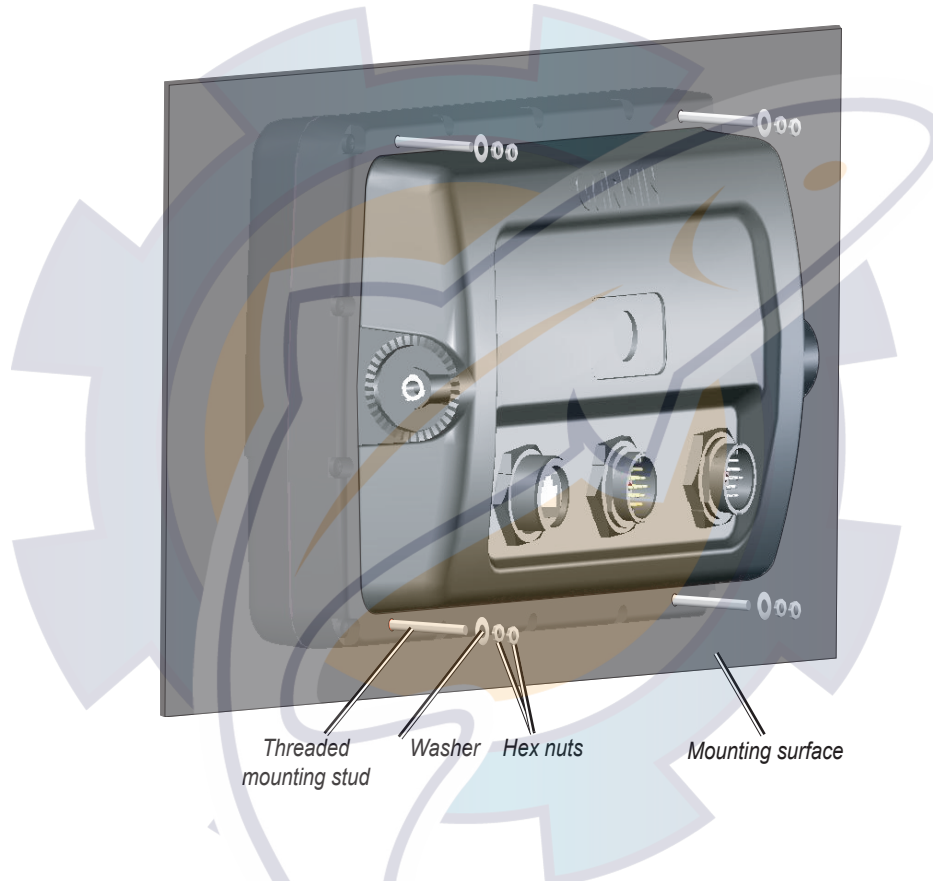

## Installing the GPS Antenna

To install the GPS 17x antenna, select a suitable location, mount the antenna, and connect the antenna to power and to your GPSMAP 3000 series chartplotter.

### Mount the GPS 17x Antenna

You can surface mount the GPS 17x antenna, attach it to a standard 1 in. OD pipe-threaded-pole marine mount (14 threads-per-inch—not included), or even install the antenna under fiberglass.

Select a suitable location for the GPS 17x antenna on your boat. To ensure the best reception, mount the GPS 17x antenna in a location that has a clear, unobstructed view of the sky in all directions.

- Avoid mounting the GPS 17x antenna where it is shaded by the superstructure of the boat, a radome antenna, or mast.
- On a sailboat, avoid mounting the GPS 17x antenna high on the mast, to prevent inaccurate speed readings caused by excessive heeling.

- The GPS 17x antenna provides more-stable readings when located nearer to water level.
- **Mount the GPS 17x antenna at least 3 ft. (1 m) away from (preferably above) the path of any radar beam or a VHF radio antenna.**
- Temporarily secure the antenna in the preferred mounting location and test it for correct operation. If you experience interference with other electronics, try a different location. When you verify correct operation, permanently mount the antenna.

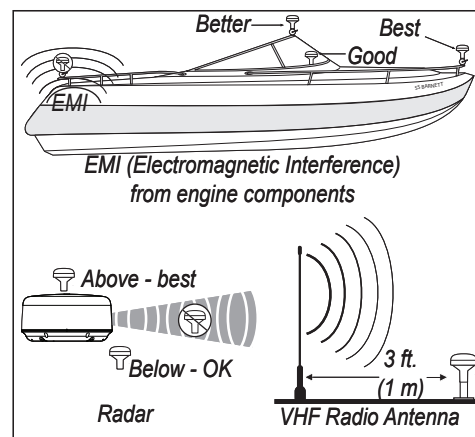

**GPS 17x Placement Considerations**

## Surface-mounting the GPS 17x Antenna

1. Use the surface-mount bracket as your mounting template
  - Use the center punch to mark the three screw locations on the surface.
  - Use a pencil to trace the cable hole in the center of the bracket.
  - Set the surface-mount bracket aside. Do not drill through the surface-mount bracket.
2. Drill the three 1/8 in. (3 mm) pilot holes.

**NOTE:** If you are mounting the GPS 17x on fiberglass, it is recommended to use a countersink bit to drill a clearance counterbore through the top gelcoat layer (but no deeper). This will help to avoid cracking in the gelcoat layer when the screws are tightened.

3. Use a 1 in. (25 mm) hole saw to cut the cable hole in the center.
4. Place the seal pad on the bottom of the surface-mount bracket. Make sure that the screw holes align.
5. Use the included M4 screws to attach the surface-mount bracket to the mounting surface.
6. Route the GPS 17x cable through the 1 in. cable hole and connect it to the GPS 17x.
7. Make sure the large gasket is in place on the bottom of the GPS 17x antenna, place the antenna on the surface-mount bracket **1**, and twist it clockwise to lock it in place **2**.
8. Secure the antenna to the mounting bracket with the included M3 set screw **3**.
9. Route the GPS 17x cable away from sources of electronic interference, and connect it to power and to your GPSMAP 3000 series chartplotter ([Page 6](#)).

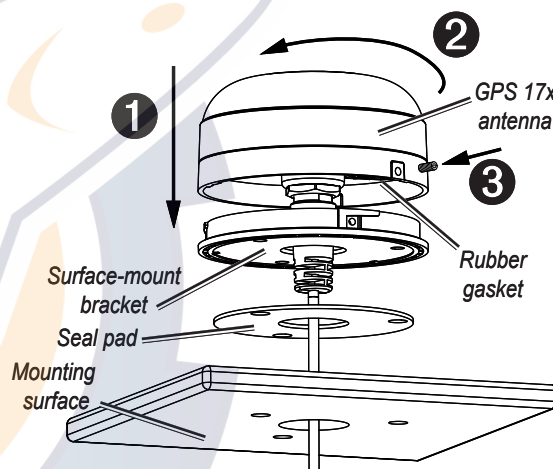

## Pole Mounting the GPS 17x Antenna

With the pole-mount adapter attached to the GPS 17x, you can install the GPS 17x on a standard 1 in. OD pipe-threaded-pole marine mount (14 threads per inch—not included). You can run the GPS 17x cable through the pole or outside the pole.

### To mount the GPS 17x with the cable run outside the pole:

1. Route the GPS 17x drop cable through the pole-mount adapter, and place the cable in the vertical slot along the base of the pole-mount adapter.
2. Thread the pole-mount adapter onto a standard 1 in. OD pipe-threaded-pole marine mount (14 threads per inch—not included). Do not overtighten the adapter.
3. Connect the GPS 17x cable to the GPS 17x antenna.
4. Place the GPS 17x antenna on the pole-mount adapter **1** and twist it clockwise to lock it in place **2**.
5. Secure the antenna to the adapter with the included M3 set screw **3**.
6. (Optional) With the GPS 17x installed on the pole mount, fill the remaining gap in the vertical cable slot with a marine sealant.
7. Attach the marine mount to the boat if it is not already attached.
8. Route the GPS 17x cable away from sources of electronic interference, and connect it to power and to your GPSMAP 3000 series chartplotter ([Page 6](#)).

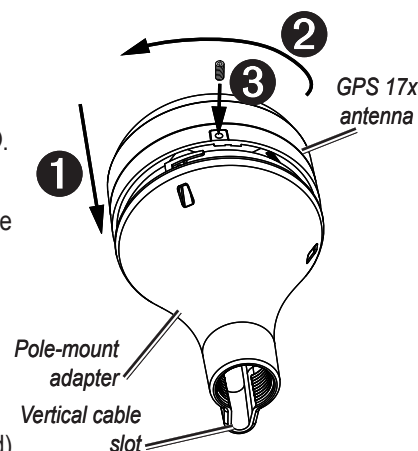

### To mount the GPS 17x with the cable run through the pole:

1. Position a standard 1 in. OD pipe-threaded-pole marine mount (14 threads per inch—not included) in the preferred location, and mark the approximate center of the pole.
2. Drill a hole using a 3/4 in. (19 mm) drill bit for the cable to pass through.
3. Fasten the marine mount to the boat.

4. Thread the pole-mount adapter onto the pole. Do not overtighten the adapter.
5. Route the GPS 17x cable through the pole and connect it to the GPS 17x antenna.
6. Place the GPS 17x antenna on the pole-mount adapter ❶ and twist it clockwise to lock it in place ❷.
7. Secure the antenna to the adapter with the included M3 set screw ❸.
8. (Optional) With the GPS 17x installed on the pole mount, fill the vertical cable slot with a marine sealant.
9. Route the GPS 17x cable away from sources of electronic interference, and connect it to power and to your GPSMAP 3000 series chartplotter (Page 6).

### Under-deck-mounting the GPS 17x Antenna

The GPS 17x can be mounted under a fiberglass surface with the included adhesive pads. The GPS 17x will not acquire satellite signals through metal—you can only use the under-deck mount under a fiberglass surface.

1. Determine the location on the fiberglass surface where you want to mount the GPS 17x.
2. Place the adhesive pads on the under-deck mounting bracket.

There are holes in the under-deck mounting bracket that can be used to secure the under-deck mount to the mounting surface with screws. Garmin does not recommend attaching the under-deck mounting bracket to the surface with screws, because of the likelihood that screws will extend beyond the top of the mounting surface. If you choose to use screws, do so with extreme care.

3. Place the GPS 17x in the under-deck mounting bracket.
4. Adhere the under-deck mounting bracket to the mounting surface.
5. Connect the GPS 17x cable to the GPS 17x.
6. Route the GPS 17x cable away from sources of electronic interference, and connect it to power and to your GPSMAP 3000 series chartplotter (Page 6).

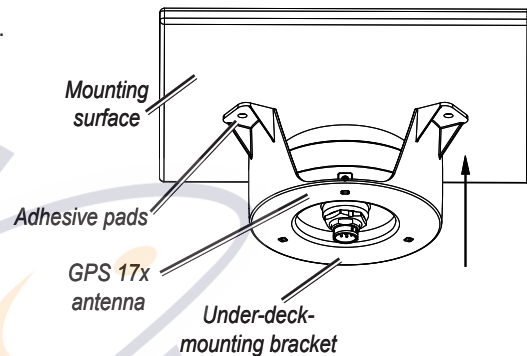

## Wiring and Cables

The GPSMAP 3000 series chartplotter comes with a Power/data cable, and a GPS 17x cable. Additionally, the GPSMAP 3006, 3206, 3010, and 3210 chartplotters come with a 17-pin Marine Video cable. Optional Garmin Marine Network components use specialized Garmin Network cables. Depending on the installation, it may be necessary to drill holes to route the connector end of these cables.

Garmin rubber grommets are provided to cover these holes for a finished look.

You may not need the grommets in some installations. The grommets do NOT create a waterproof seal. Apply a marine sealant around the grommet and cable after installation. Be sure to test the system before installing and sealing the grommets. Purchase additional grommets from your Garmin dealer or directly from Garmin at [www.garmin.com](http://www.garmin.com).

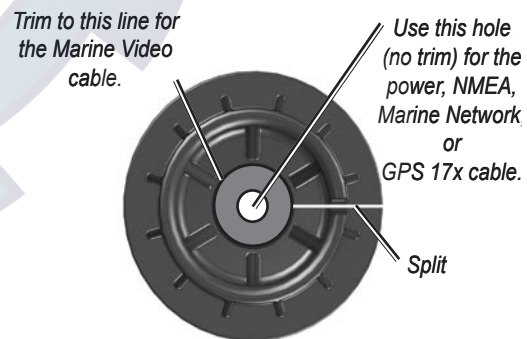

### Tools

- Drill
- 1 1/4 in. (31.7 mm) paddle drill bit or hole saw
- Utility knife
- Marine sealant (optional)

### To install the cable grommet:

1. Mark the location where you want to route the cable (Power/data, GPS 17x, Marine Video, or Marine Network.)
2. Using a 1 1/4 in. (31.7 mm) paddle drill bit or hole saw, drill the installation hole.
3. Refer to the diagram for trimming instructions. Carefully trim the cable hole in the grommet, as needed.
4. Route the cable to the chartplotter, and test the system.
5. Spread the grommet apart at the split and place it around the cable.
6. Firmly push the grommet into the installation hole until it is seated. Apply marine sealant, as needed, to weatherproof the cable.

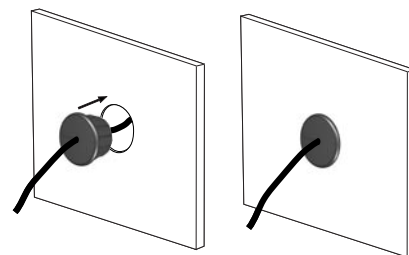

## Power/Data Cable Wiring

The following pages contain several wiring diagrams. The first diagram on the next page is a simple diagram showing the GPSMAP 3000 series chartplotter using the 18-pin Power/data cable and the GPS 17x. If two or more GPSMAP 3000, 4000, or 5000 series chartplotters are installed and networked, only one GPS 17x antenna needs to be installed. Next are wiring diagram examples showing the GPSMAP 3000 using the 18-pin Power/Data wiring harness interfacing with a variety of different equipment. Refer to the wiring diagram that best suits your needs. For third-party devices, refer to the wiring guidelines included with that equipment. Use 22 AWG (18 AWG for the Red and Black wires), shielded, twisted-pair wiring for extended runs of wire. Solder all connections and seal the connection with heat shrink tubing. **If networking two or more chartplotters, the GPS 17x and NMEA input devices should only be attached to one chartplotter on the network.** A pinout of the cable is shown below.

### Power/Data Cable Input/Output Ports

The GPSMAP 3000 series Power/data cable has four I/O (Input/Output) ports.

**Ports 1 and 2**—communicate with other NMEA-compliant devices, such as VHF radios, NMEA instruments, autopilots, or PCs (Port 1 only). You can input **one** NMEA device to each port, and output in parallel to **three** NMEA devices per port.

**Port 3**—is reserved for use with Garmin sounder modules.

**Port 4**—is reserved for use with the Garmin GPS 17x GPS antenna.

The following formats are supported for connection of external devices: Garmin proprietary sonar module and NMEA 0183 version 3.01. The following are the sentences for NMEA 0183, version 3.01 and later output:

**Approved sentences**—GPBWC, GPRMC, GPGGA, GPGSA, GPGSV, GPGLL, GPBOD, GPRMB, GPRTE, GPVTG, GPWPL, and GPXTE

**Garmin proprietary sentences**—PGRME, PGRMM, PGRMZ, and PSLIB

The unit also includes NMEA input with support for the WPL sentence, DSC, and sonar NMEA input with support for the DPT (Depth) or DBT, MTW (Water Temp), and VHW (Water, Speed, and Heading) sentences. The unit interface must be set to **NMEA In/NMEA Out**.

Documentation concerning NMEA and RTCM formats and sentences are available for purchase from:

National Marine Electronics Association (NMEA)  
 Seven Riggs Avenue  
 Severna Park, MD 21146  
 U.S.A.  
[www.nmea.org](http://www.nmea.org)

Function	Color	Pin #
DC power input	Red	15
Ground (Power/data)	Black	18
Port 1: Data in (Rx)	Brown	16
Port 1: Data out (Tx)	Blue	17
Port 2: Data in (Rx)	Violet	9
Port 2: Data out (Tx)	Gray	10
Port 3: Data in (Rx)	White/Brown	4
Port 3: Data out (Tx)	White/Blue	5
Accessory on signal	Orange	6
Port 4: Data in (GPS 17x)	White	13
Port 4: Data out (GPS 17x)	Green	14
Alarm low signal	Yellow	11
No function	No color	1,2,3,7,8,12

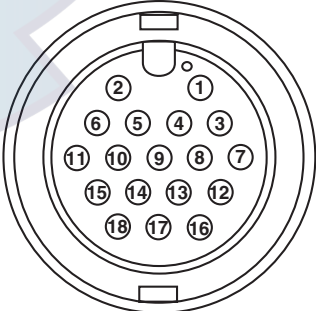

**Cable End View**

**Power/Data(NMEA) Cable**

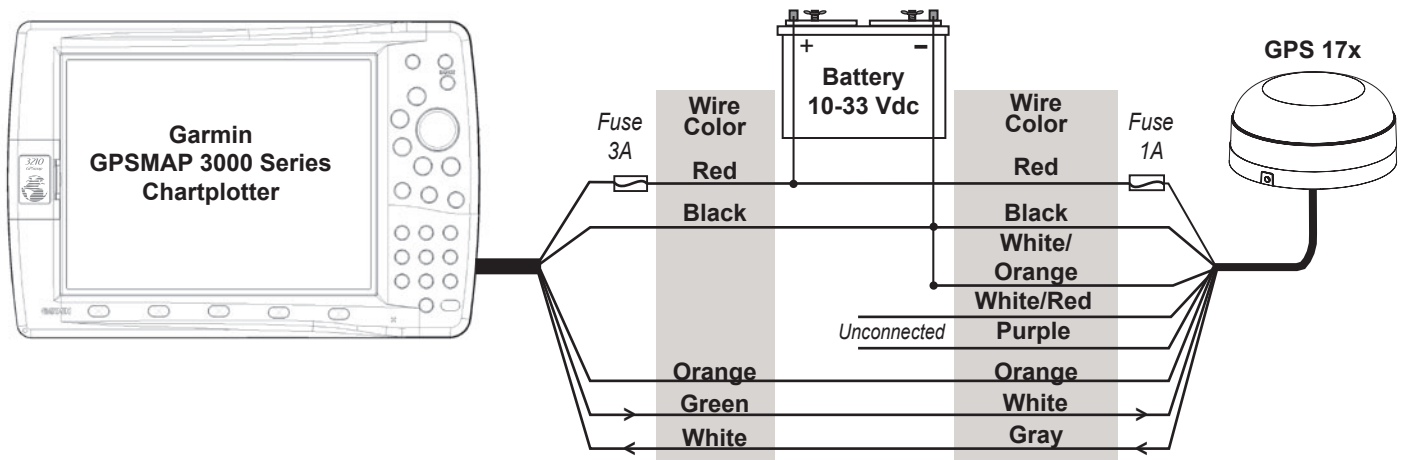

GPSMAP 3000 Series Chartplotter Wired to a GPS 17x

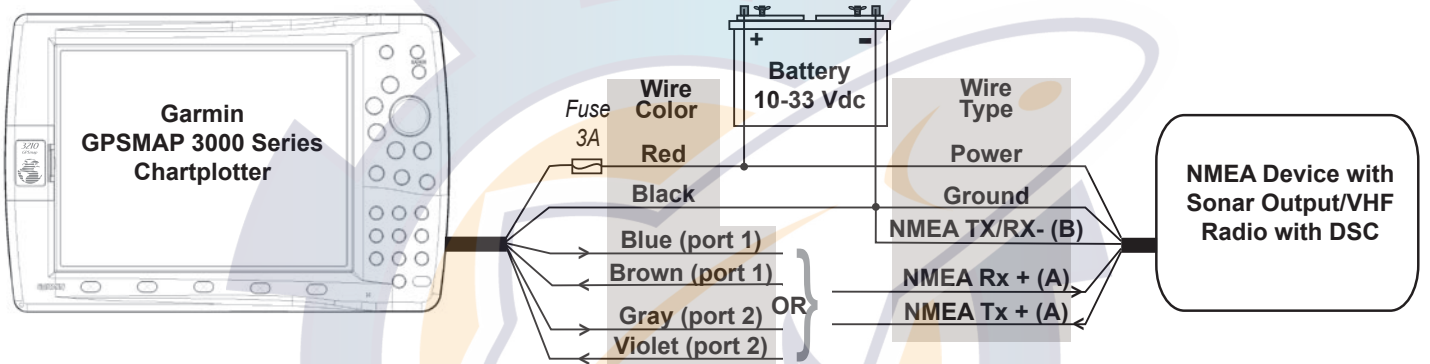

GPSMAP 3000 Series Chartplotter Wired to a NMEA Device With Two-way Communication

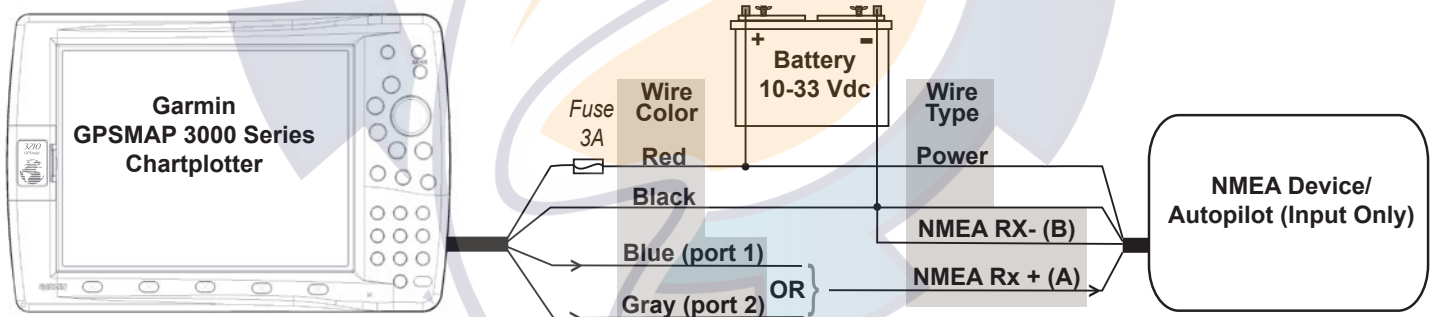

GPSMAP 3000 Series Chartplotter Wired to a NMEA Device With One-way Communication

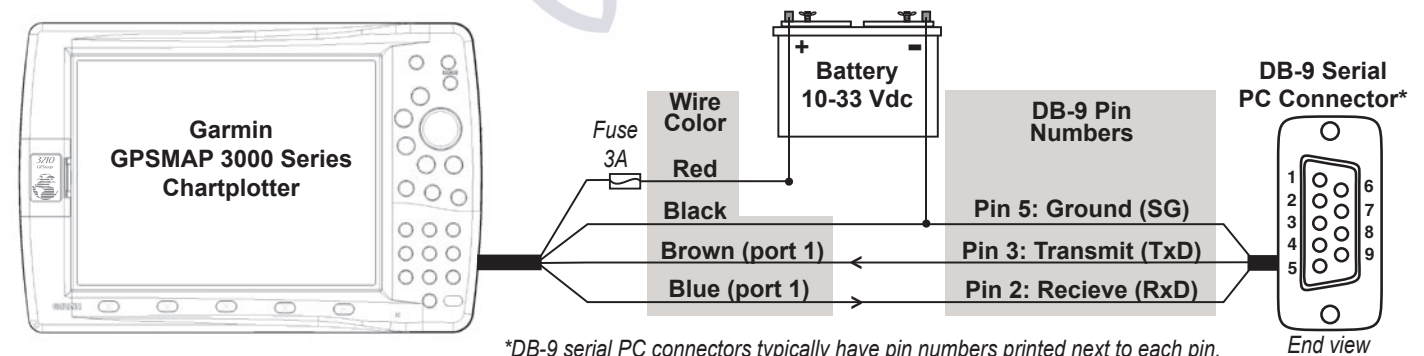

\*DB-9 serial PC connectors typically have pin numbers printed next to each pin.

GPSMAP 3000 Series Chartplotter Wired to a DB-9 Serial PC Connector

## Wiring to an Optional Alarm

The GPSMAP 3000 series chartplotter can be used with a lamp, a horn, or both, to sound or flash an alert when the chartplotter displays a message. The alarm does not need to be wired for the GPSMAP 3000 chartplotter to function. The alarm circuit switches to a low-voltage state when the alarm sounds. The maximum current is 100 mA, and a relay (not included) is needed to limit the current from the chartplotter to 100 mA. To select between visual and audible alerts, install a switch.

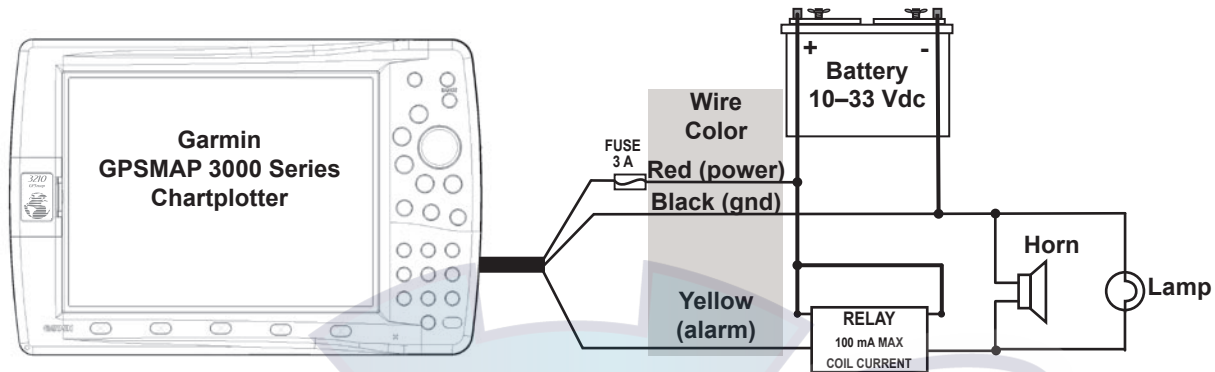

Wiring to a lamp, a horn, or both.

## Marine Video Cable

The GPSMAP 3006/3206/3010/3210 chartplotters have video input and output capabilities, and a video cable is provided with those units. The GPSMAP 3005/3205 chartplotters do not have video input or output capabilities, so no cable is provided with those units.

The Marine Video 17-pin cable allows input of NTSC (National Television System Committee)/PAL (Phase Alternate Line) composite video sources, and PC monitor output. Marine Video inputs are only available on the chartplotter to which they are attached and **will not** transmit over the Garmin Marine Network.

- ❶ and ❷ VIDEO 1 and VIDEO 2 Inputs (RCA connectors) allow input from two separate NTSC/PAL compatible video devices, such as VCR, DVD, TV, or a video camera. The chartplotter can display one video input at a time or alternate between the two. See the owner's manual for details. Sound from a video source must be attached to a separate stereo/audio system. The video output from video device attaches to the Video 1 (Black Cable) or Video 2 (Gray Cable) RCA connectors.
- ❸ Use the PC monitor output (HD 15-pin) connector for remote viewing of the chartplotter display on a computer monitor. The remote monitor must be capable of at least VGA resolution and have multi-sync capability.

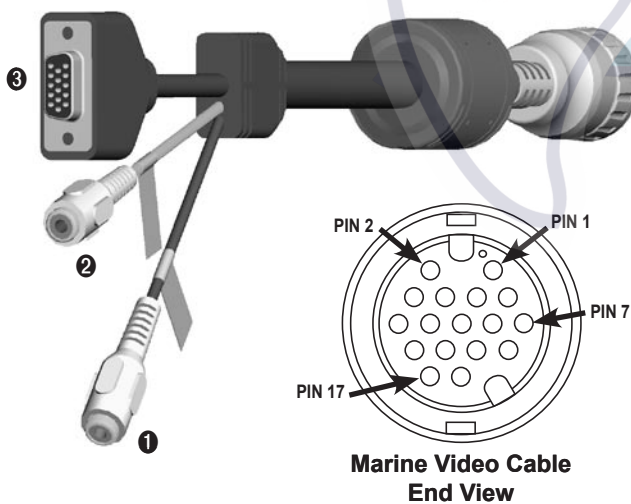

Note	Connector	Pin	Function
❶	RCA-1 Center	2	Video 1 in (black jacket)
	RCA-1 Outer	6	Video 1 in, gnd
❷	RCA-2 Center	11	Video 2 in (gray jacket)
	RCA-2 Outer	15	Video 2 in, gnd
❸	HD-15 Pin 1	1	VGA, analog-red
	HD-15 Pin 2	4	VGA, analog-green
	HD-15 Pin 3	3	VGA, analog-blue
	HD-15 Pin 5	13	VGA, analog, gnd
	HD-15 Pin 6	8	VGA, analog-red, gnd
	HD-15 Pin 7	8	VGA, analog-green, gnd
	HD-15 Pin 8	8	VGA, analog-blue, gnd
	HD-15 Pin 10	13	VGA, sync-Gnd
	HD-15 Pin 13	7	VGA, H-sync
	HD-15 Pin 14	12	VGA, V-sync
	HD-15 Pin shell	9	VGA, overall shield



## Garmin Marine Network

The Garmin Marine Network is a waterproof ethernet-based system that allows Garmin chartplotters to communicate with Garmin sensors and other Garmin chartplotters over the network. Waterproof RJ-45 connections allow for simple installation and high-speed connectivity. For a simple installation with one Garmin chartplotter and one Garmin sensor, the two devices can be directly connected with a Garmin Marine Network cable.

**NOTE:** Power connections for network components are not shown in the following illustrations. All components of the Garmin Marine Network must be connected to power, because they do not receive power through the network connections.

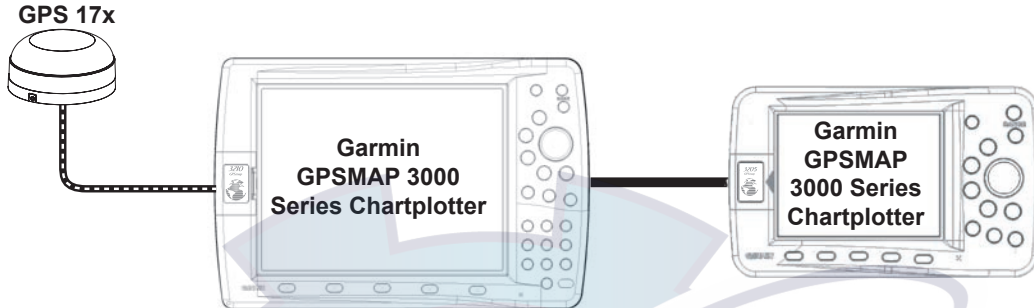

Simple Garmin Marine Network With Two Chartplotters

If more than two GPSMAP 3000 series chartplotter are installed, use a Garmin Marine Network Port Expander (GMS 10) to expand the network. If two or more GPSMAP 3000 series chartplotters are installed and networked, only one GPS 17x antenna needs to be installed. You can add up to five total devices to the Network Port Expander. If more than five are needed, you can add more Network Port Expanders to the network. This network is NOT compatible with PC networks. **Do NOT attach PC devices to the Garmin Marine Network.** Some examples of the Garmin Marine Network are included below. Refer to the individual installation instructions for the individual sensors. Additional Garmin network cables are available from your Garmin dealer or direct from Garmin.

You can also include GPSMAP 4000/5000 series chartplotters in your Garmin Marine Network. Refer to the GPSMAP 4000/5000 Series Installation Instructions for more information.

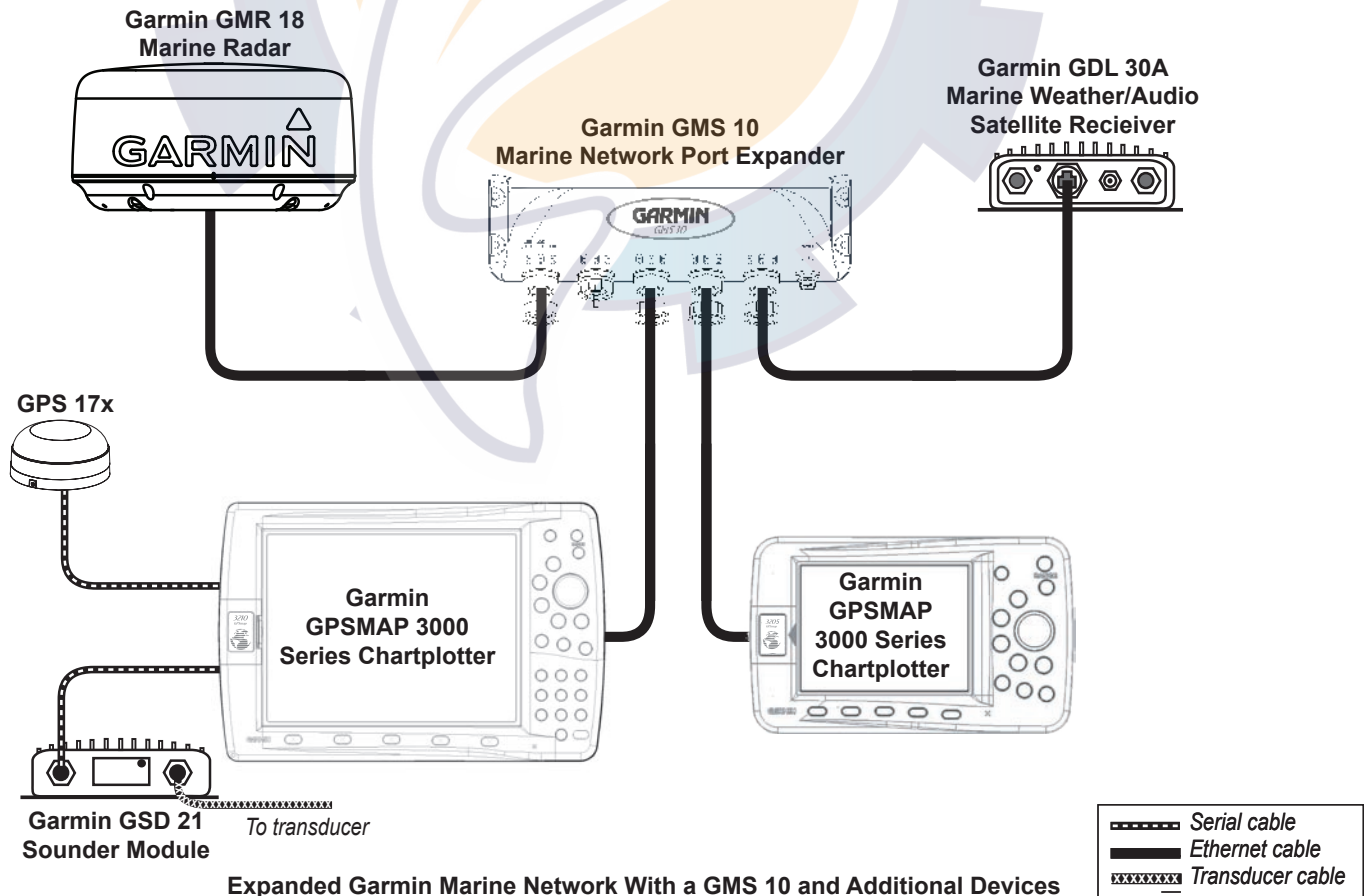

Expanded Garmin Marine Network With a GMS 10 and Additional Devices

## Final Wiring Connection

After all the wiring is complete, the cables are attached on the backside of the GPSMAP 3000 series chartplotter. If the chartplotter is not connected to a Garmin Marine Network, be sure to firmly affix the weather cap over the open connector to limit corrosion of the contacts. The connection ports are labeled on the back of the chartplotter.

### To install the Power/NMEA, Marine Video, and Network Cables:

1. Align the notch and locking ring tab on the black Power/NMEA cable with the black **POWER/NMEA** port on the back of the unit. Carefully press the cable in until it is firmly seated. **Do not force the cable, because this may damage the pins.**
2. After the cable is seated, turn the locking ring clockwise until it stops.
3. Repeat Steps 1 and 2, attaching the gray Marine Video cable to the gray **VIDEO** port on the back of the unit.
4. If you are connecting the GPSMAP 3000 series chartplotter to a Garmin Marine Network, insert the RJ-45 connector into the **NETWORK** port on the back of the unit and screw the locking ring in clockwise until it is firmly seated.

With power applied to the circuit, test the installation by pressing the **POWER** key on the front of the unit. Refer to your GPSMAP 3000 series Owner's Manual for steps on initializing and using the chartplotter.

## Updating the Chartplotter Software

Your GPSMAP 3000 series chartplotter may contain a software update Data card. If so, follow the instructions provided with the card.

If a software update Data card is not included, visit [www.garmin.com](http://www.garmin.com) to make sure your chartplotter software is up-to-date. If your software is not up to date, follow the directions on [www.garmin.com](http://www.garmin.com), or contact [www.garmin.com/support](http://www.garmin.com/support).

### To determine the version of software on your chartplotter:

1. Hold **ADJ/Menu** to open the Main Menu.
2. Select **System > Update** to view the installed software version.

For the latest free software updates (excluding map data) throughout the life of your Garmin products, visit the Garmin Web site at [www.garmin.com](http://www.garmin.com).

**GARMIN**®

© 2008 Garmin Ltd. or its subsidiaries

Garmin International, Inc.  
1200 East 151<sup>st</sup> Street, Olathe, Kansas 66062, USA

Garmin (Europe) Ltd.  
Liberty House, Hounsdown Business Park, Southampton, Hampshire, SO40 9RB UK

Garmin Corporation  
No. 68, Jangshu 2<sup>nd</sup> Road, Shijr, Taipei County, Taiwan

[www.garmin.com](http://www.garmin.com)

Part Number 190-00991-02 Rev. A